

MANUAL GRIND

If you prefer, after selecting your grind setting, you have the option of manually controlling how much coffee the unit will grind. To do so, follow steps 1-4 on previous page. Then press and hold the manual button until the desired amount of coffee has been ground. The LCD will display M.

NOTE: To avoid overflow when using the manual feature, the grinder will automatically stop grinding when the maximum capacity has been reached.

GRINDING SETTINGS

When selecting your grind setting remember that the higher the number the coarser the grind. Use 1-6 for Espresso, 7-12 for Auto Drip, and 13-18 for French Press.

CLEANING/MAINTENANCE INSTRUCTIONS

1. Be sure plug has been removed from outlet.
2. Beans can be removed from the hopper by lifting off the lid and pouring excess beans out. Hold down the Manual button to cleanout any remaining beans.
3. The bean hopper, bean hopper lid, grind chamber, and grind chamber lid can be washed by hand with hot, soapy water or placed in the top shelf of a dishwasher. Dry thoroughly.
 - a. Remove the bean hopper by rotating counter-clockwise bringing the selector past grind setting 18, align the arrows and lift up. Make sure the hopper is empty.
 - b. Remove grind chamber by pulling toward you.
4. Remove the burr grinder, once the bean hopper has been removed, by grasping the metal handle and lifting up. Use the brush to remove grinds or wash by hand. Replace the burr grinder onto the unit and rotate until the piece is fully inserted. Push handle down and replace hopper.

NOTE: The hopper will not attach to the unit if the grinder has not been fully inserted.

5. Wipe body of grinder with a damp cloth.
6. Any other servicing or maintenance should be performed by an authorized service representative.

WARNING: NEVER IMMERSIVE UNIT IN WATER

WARRANTY

The Cuisinart® Programmable Conical Burr Mill carries a Limited 18-Month Warranty. This warranty is available to consumers only. You are a consumer if you are the owner of a Cuisinart® Programmable Conical Burr Mill that was purchased at retail for personal, family, or household use. Except as otherwise required by applicable state law, this warranty is not available to retailers or other commercial purchasers or owners.

We warrant that should your Cuisinart® Programmable Conical Burr Mill prove to be defective within the warranty period, we will repair it or replace it at our option, without charge to you. We recommend that you visit our website, www.cuisinart.com for a fast, efficient way to complete your product registration. However, product registration does not eliminate the need for the consumer to maintain the original proof of purchase in order to obtain the warranty benefits. In the event that you do not have proof of purchase date, the purchase date for purposes of this warranty will be the date of manufacture. To obtain warranty service, simply call our toll-free number: 800-726-0190, for additional information from our Consumer Service Representatives, or send the product to Consumer Service at Cuisinart, 7811 North Glen Harbor Blvd., Glendale, AZ 85307. To facilitate the speed and accuracy of your return, please enclose a check or money order for \$4.00 for shipping and handling.

(California residents need only supply proof of purchase and should call 1-800-726-0190 for shipping instructions.) **NOTE:** For added protection and secure handling of any Cuisinart® product that is being returned, we recommend you use a traceable, insured delivery service. Cuisinart cannot be held responsible for in-transit damage or for packages that are not delivered to us. Lost and/or damaged products are not covered under warranty. Your Cuisinart® Programmable Conical Burr Mill has been manufactured to strict specifications and has been designed for use with the Cuisinart® Programmable Conical Burr Mill authorized accessories and replacement parts for your model. These warranties expressly exclude any defects or damages caused by accessories, replacement parts or repair service other than those that have been authorized by Cuisinart. These warranties exclude all incidental or consequential damages. Some states do not allow the exclusion of or limitation of incidental or consequential damages, so the foregoing limitation or exclusion may not apply to you.

CALIFORNIA RESIDENTS ONLY

California law provides that for In-Warranty Service, California residents have the option of returning a nonconforming product (A) to the store where it was purchased or (B) to another retail store which sells Cuisinart products of the same type. The retail store shall then, according to its preference, either repair the product, refer the consumer to an independent repair facility, replace the product, or refund the purchase price less the amount directly attributable to the consumer's prior usage of the product. If the above two options do not result in the appropriate relief to the consumer, the consumer may then take the product to an independent repair facility if service or repair can be economically accomplished. Cuisinart and not the consumer will be responsible for the reasonable cost of such service, repair, replacement, or refund for nonconforming products under warranty. California residents may also, according to their preference, return nonconforming products directly to Cuisinart for repair or, if necessary, replacement by calling our Consumer Service Center toll-free at 800-726-0190. Cuisinart will be responsible for the cost of the repair, replacement, and shipping and handling for such nonconforming products under warranty.

BEFORE RETURNING YOUR CUISINART PRODUCT

Important: If the nonconforming product is to be serviced by someone other than Cuisinart's Authorized Service Center, please remind the servicer to call our Consumer Service Center to ensure that the problem is properly diagnosed, the product serviced with the correct parts, and to ensure that the product is still under warranty.

IB-8304A

©2010 Cuisinart
150 Milford Road, East Windsor, NJ 08520
Printed in China 10CE113938

Cuisinart®



Programmable Conical Burr Mill

CBM-18

IMPORTANT SAFEGUARDS

When using electrical appliances, basic safety precautions should always be followed, including the following:

1. Read all instructions.
2. To protect against risk of electrical shock, do not immerse cord, plug or grinder in water or other liquid.
3. Close supervision is necessary when any appliance is used by or near children.
4. UNPLUG FROM OUTLET WHEN NOT IN USE, BEFORE PUTTING ON OR TAKING OFF PARTS, BEFORE REMOVING COFFEE AND BEFORE CLEANING.
5. Avoid contact with moving parts.
6. Do not operate any appliance with a damaged cord or plug, or after the appliance malfunctions, or is dropped or damaged in any manner. Return appliance to the nearest authorized Cuisinart service facility for examination, repair, or mechanical or electrical adjustment.
7. The use of attachments not recommended or sold by Cuisinart may cause fire, electrical shock, or risk of injury.
8. Do not use outdoors.
9. Do not let cord hang over edge of table or counter, or touch hot surfaces.
10. Before using, check hopper for presence of foreign objects.
11. Use this appliance to grind roasted coffee beans only. Grinding other substances, such as nuts, spices or unroasted beans, may dull the blade and cause poor grinding or injury.
12. Do not use appliance for other than intended use.
13. Do not place this appliance on or near a hot gas or electric burner, or in a heated oven.

SAVE THESE INSTRUCTIONS FOR HOUSEHOLD USE ONLY

NOTICE

This appliance has a polarized plug (one blade is wider than the other). To reduce the risk of electric shock, this plug will fit in a polarized outlet only one way. If the plug does not fit fully in the outlet, reverse the plug. If it still does not fit, contact a qualified electrician. Do not modify the plug in any way.

INTRODUCTION

The next generation of coffee grinders has arrived to deliver the new standard in home-ground coffee! The conical burrs grind the beans with precise uniformity while maintaining the full flavor of the coffee bean. Whether you're using a French Press, Auto Drip or Espresso machine, you'll always start with the best, most precise ingredients. This grinder is fully automated – just choose your grind setting and number of cups, push Start, and the LCD with countdown timer lets you know how soon you'll have your perfectly ground coffee!

OPERATING INSTRUCTIONS

1. Remove bean hopper lid.
2. Fill bean hopper, making sure that the lid closes securely. Maximum capacity is 8 oz, be sure you have enough beans to grind your desired amount of coffee.
3. Plug cord into outlet.
4. Select grind setting – turn the hopper to your desired grind setting. The higher the number the coarser the grind. Use 1-6 for Espresso, 7-12 for Auto Drip, 13-18 for French Press. Your current selection will be displayed on the LCD.
5. Select cup setting – press the # of Cups repeatedly until your desired number of cups is displayed on the LCD, from 2 to 14 cups. Press and hold the button to scroll through the numbers quickly.
6. Press the Start/Stop button to begin grinding.
A safety interlock system prevents the unit from operating unless the hopper and grind chamber are properly in place.
Note: If the grind chamber is overfilled the chute can get clogged and the unit will not work. The LCD will flash. To unclog, use the scoop brush to clear out the chute of excess grounds.
Also note: If the grinder stops and displays HHH in the LCD screen at any point, the motor has likely over-heated. Wait approximately 2 minutes for your grinder to cool off; when the HHH is no longer displayed, resume use.
7. Grinding will automatically stop upon completion.
Note: to pause or cancel operation during use, see below.
8. Pull the grind chamber toward you to remove from unit.

TO PAUSE OR CANCEL GRINDING

- a. To pause the grinding, press the Start/Stop button. The grinder will stop and the countdown timer will flash. Press the Start/Stop button again to resume.
- b. To cancel the grinding, press and hold the Start/Stop button for 2-3 seconds.

NOTE: The unit will pause for up to 5 minutes before cancelling the grind.

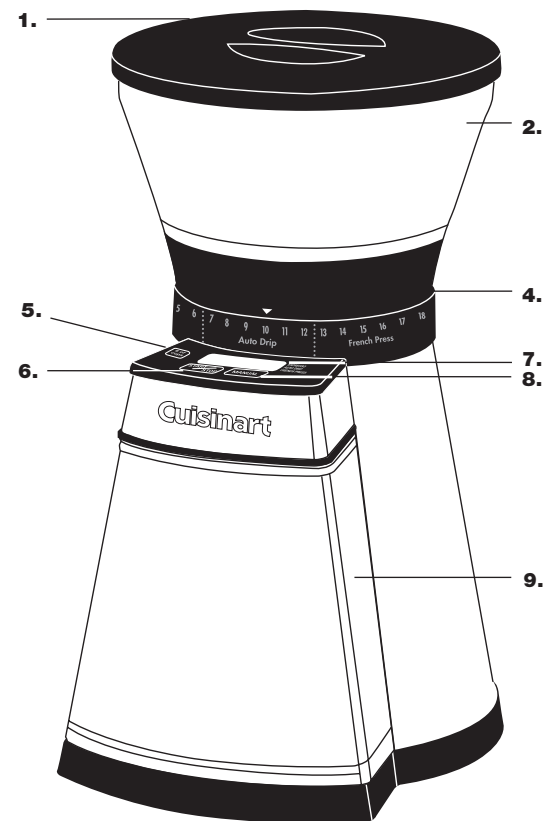

- | | |
|-------------------------------------|---|
| 1. Hopper Lid | 7. LCD Display |
| 2. Bean Hopper | 8. Manual Button |
| 3. Conical Burr Grinder (not shown) | 9. Grind Chamber with Lid |
| 4. Grind Selector | 10. Cord Storage |
| 5. Cup Selector | 11. BPA-Free (not shown) |
| 6. Start/Stop Button | All parts that come in contact with coffee are BPA-Free |