

# Cuisinart®



Automatic Brew & Serve

DTC-850  
Series

For your safety and continued enjoyment of this product, always read the instruction book carefully before using.

---

# IMPORTANT SAFEGUARDS

When using electrical appliances, basic safety precautions should always be followed to reduce the risk of fire, electric shock and/or injury to persons, including the following:

1. Read all instructions before operating or using the appliance.
2. Do not touch hot surfaces. Use handles and knobs.
3. To protect against electrical shock, do not place cord, plugs or appliance in water or other liquid.
4. Close supervision is necessary when any appliance is used by or near children.
5. Unplug from outlet when not in use and before cleaning. Allow to cool before putting on or taking off parts and before cleaning the appliance.
6. Do not operate any appliance with damaged cord or plug, or after the appliance malfunctions or has been damaged in any manner. Return appliance to authorized service facility for examination, repair or adjustment.
7. The use of an accessory not evaluated for use with the appliance may cause injuries.
8. Do not use outdoors.
9. Do not let cord hang over edge of table or counter, or touch hot surface.
10. Do not place on or near a hot gas or electric burner or in a heated oven.
11. Do not move entire unit when appliance is on or when thermal carafe contains hot liquids.
12. Prior to connecting or disconnecting plug from wall outlet, turn all controls to "OFF".
13. Do not use appliance for other than intended purpose. Appliance is for household use only.
14. **WARNING:** To reduce risk of fire or electrical shock, do not remove bottom cover. No user-serviceable parts are inside. Repair should be

done by authorized personnel only.

15. Special instructions for the thermal carafe:
  - A. The thermal carafe is designed for use with this appliance only. It must never be used with any other drip-type coffee maker, or on a range top or in a microwave oven.
  - B. Do not set a hot thermal carafe on a wet or cold surface. Do not put thermal carafe in water. Do not place on hot surface.
  - C. Do not use a cracked thermal carafe or a thermal carafe that has a loose or weakened handle. If glass liner breaks, do not consume beverage.
  - D. Do not clean thermal carafe with cleaners, steel wool pads or abrasive material. Do not place sharp or hard objects in the thermal carafe.

## SAVE THESE INSTRUCTIONS HOUSEHOLD USE ONLY

### SPECIAL CORD SET INSTRUCTIONS

A short power-supply cord is provided to reduce the risk of becoming entangled in or tripping over a longer cord.

Extension cords are available and may be used if care is exercised in their use.

If an extension cord is used, the marked electrical rating of the extension cord should be at least as great as the electrical rating of the appliance, and the cord should be arranged so it will not drape over the countertop or tabletop where it can be tripped over or pulled on by children.

## WARNING: RISK OF FIRE OR ELECTRIC SHOCK



The lightning flash with arrowhead symbol, within an equilateral triangle, is intended to alert the user to the presence of uninsulated "dangerous voltage" within the product's enclosure that may be of sufficient magnitude to constitute a risk of fire or electric shock to persons.



The exclamation point within an equilateral triangle is intended to alert the user to the presence of important operating and maintenance (servicing) instructions in the literature accompanying the appliance.

## NOTICE

This appliance has a polarized plug (one blade is wider than the other). To reduce the risk of electric shock, this plug is intended to fit into a polarized outlet only one way. If the plug does not fit fully into the outlet, reverse the plug. If it still does not fit, contact a qualified electrician. Do not attempt to modify the plug in any way.

## UNPACKING INSTRUCTIONS

Place the box on a large, sturdy, flat surface. Lay the box on its side. Slide the packaged unit out of the box. Remove the foam insert and the cardboard insert. Now remove the carafe from the coffee maker. Carefully lift the coffee maker from the remaining inserts. Remove the plastic bag from the coffee maker. We suggest you save all packing materials in the event that future shipping of the machine is needed. Keep all plastic bags away from children.

## TABLE OF CONTENTS

Important Safeguards	p.1
Unpacking Instructions	p.2
Introduction	p.2
Using the Programming Feature	p.2
Coffee Preparation	p.3
About the Thermal Carafe	p.4
Cleaning and Maintenance	p.4
Features and Benefits	p.5
Warranty	p.6

## INTRODUCTION

The Cuisinart® Automatic Brew and Serve Coffee Maker is a coffee lover's dream. It delivers the freshest coffee in the world. The secret? The patented lid. Coffee brews and pours through without ever having to open or turn the lid. Flavor and

heat are sealed in. Now, you can program your coffee maker to start brewing when you want. Simply set the desired brew time, fill the reservoir with water, put in your filter, add ground coffee and press the "ON" button. In minutes, you'll have a wonderfully fresh pot of coffee.

We know the Cuisinart® Automatic Brew and Serve will bring you years of pleasure. Nothing is more satisfying than a rich cup of your favorite brew.

## DESCRIPTION OF PARTS

Your thermal carafe coffee maker brews fresh, filtered coffee in minutes. The thermal carafe contains a vacuum-sealed glass inner liner which delivers heat retention superior to other containers used with drip coffee makers and helps keep full coffee flavor.

Reservoir Cover  
Thermal Carafe  
Swing-Out Filter Basket  
Brew-Through Lid  
Water Level Indicator  
Pause & Serve  
Programmable Control Panel  
Carafe Platform  
Cord Storage

## PREPARATION FOR USE

Before first use, clean the thermal carafe coffee maker by completing a brew cycle as described below without using coffee or coffee filter.

## USING THE PROGRAMMING FEATURE

### To Set The Clock

To set the time, press and hold the hour or minute button for two seconds. "Time set" starts flashing in the upper left hand corner of the LCD screen.



---

Press the hour button to advance the clock to the desired time. The hour numeral moves in one hour increments. When passing 12 am, the “PM” indicator will illuminate in the lower left hand corner of the LCD screen.

Press the “minute” button to advance the minutes to the desired time. Minutes move in one second increments.

When complete, press the hour button again, or wait for 15 seconds and your time change will be accepted.

### To Program the Brew Time

To program the brew time, press and hold the program button for two seconds. The “prog” symbol starts flashing in the lower right corner of the LCD screen.

Press the hour button to advance the clock to the desired time. The hour numeral moves in one hour increments. When passing 12 am, the “PM” indicator will illuminate in the lower left hand corner of the LCD screen.

Press the “minute” button to advance the minutes to the desired time. Minutes move in one second increments.

When complete, press the “prog” button, or wait for 15 seconds and your set time will be accepted.

### To Activate the Auto Brew Cycle

To activate the auto brew mode, depress the “auto on” button. The “auto” symbol will illuminate in the upper right hand corner of the LCD screen.

The unit will now begin the brewing cycle at the programmed time. When the programmed time initiates the cycle, the red “ON” indicator light will show that the brewing cycle has started.

**NOTE: The unit will continue to attempt to brew at the programmed time, each day, until the Auto On button is turned off. The red “ON” indicator light will illuminate each time the attempt to brew is made.**

If there is no water in the reservoir, the unit will automatically shut off one minute later.

## COFFEE PREPARATION

1. Place coffee maker on a solid flat surface. Plug into 120V outlet.
2. Open thermal carafe lid in direction of “OPEN” arrow. Fill thermal carafe with cold, fresh water. Open hinged water reservoir cover; pour water into reservoir opening. Markings on water level indicator show amount of water needed to make desired number of cups of coffee.  
**TO AVOID OVERFLOW, DO NOT FILL ABOVE 8-CUP MARK.**  
Close reservoir cover.
3. Before thermal carafe is returned to platform, prewarm carafe by running warm water through carafe. If warm water is not run through carafe, when hot coffee flows into carafe during brewing cycle the glass liner may crack due to the temperature change.  
**Prewarming carafe will help keep coffee warmer, and also prevent glass liner from being damaged.**
4. Return carafe lid to thermal carafe. To close lid, turn it in direction of “CLOSE” arrow until it fits tightly on carafe, and “POUR” arrow is aligned with spout. Return empty thermal carafe to platform. Be certain thermal carafe lid is in “CLOSED” position and is securely in place during brew cycle.
5. Open filter basket by grasping basket handle and swinging outward. Insert a filter into filter basket; make sure filter fits snugly in basket. Use a fresh filter for each carafe of coffee.
6. After placing 2 level tablespoons per cup of ground coffee into cone filter, return basket to closed position. To ensure safe operation, make sure basket is closed securely.
7. With thermal carafe and basket securely in place, press “ON” button; LED will light.  
**CAUTION:** Coffee maker becomes very hot during brew cycle; handle with extreme care as hot parts and escaping steam may cause burns.
8. The Brew-Through lid allows coffee to drip from coffee maker through closed lid. When coffee has completely stopped dripping into thermal carafe and water level indicator is empty, brew cycle is complete. When dripping stops, Brew-Through lid will seal so coffee freshness and temperature are preserved.
9. An audible “beep” tone will signal when brew cycle is complete. Coffee maker will switch off automatically.
10. After coffee grounds have cooled, carefully open filter basket and discard used coffee filter

---

and grounds. To remove filter basket from coffee maker (A) grasp basket handle and swing basket outward, and (B) with basket in far right position, lift up and pull basket hinge.

11. Brew-Through lid allows coffee to be poured with lid in “CLOSED” position so coffee freshness and temperature can be preserved. NEVER POUR LIQUID FROM THERMAL CARAFE UNLESS LID IS IN “CLOSED” POSITION.

## CORD STORAGE

A cord storage area is built into the base of the coffee maker so the desired length of cord can be used.

## PAUSE & SERVE

This feature allows a cup of coffee to be poured before brew cycle has finished. Carefully remove thermal carafe, and the Pause & Serve feature will be automatically activated, temporarily stopping flow of coffee into thermal carafe. Return thermal carafe to platform immediately after pouring coffee, and the brewing process will resume.

**IMPORTANT:** Carafe must be returned to its position within 30 seconds to prevent filter basket from overflowing.

**NOTE:** Strength of coffee poured mid-cycle may vary in strength from finished brew.

**CAUTION:** During brew cycle, basket must be closed securely since basket in improper position may cause hot water or coffee to overflow.

## PRECAUTIONS

1. Do not place a cloth or otherwise restrict airflow beneath coffee maker.
2. To avoid accidents, make sure thermal carafe lid is in “CLOSED” position during brewing and while pouring; do not pour in the direction of people.
3. When pouring, use thermal carafe handle only.
4. **CAUTION:** Burns may result from spilled hot liquid and/or contact with hot parts.

## THERMAL CARAFE PRECAUTIONS

Your thermal carafe contains a vacuum-sealed double glass inner liner. Improper use will damage the liner. Please follow these instructions:

1. Clean inside of carafe with lukewarm water. Turn carafe upside down to dry.
2. Never clean inside of carafe with a hard implement, scouring pad or other abrasive cleaners; rinse only with water. Scratches in the glass may cause glass liner to weaken and break over time.
3. Never insert your hand into carafe for cleaning. A damaged glass liner can cut your hand and cause serious injuries.
4. Never stir inside of carafe with a spoon or other utensil.
5. Never fill carafe to the rim. Fill to a maximum of one inch from the top of liner.
6. Before adding very hot or very cold liquid to carafe, first rinse with warm or cold water, depending upon what is being prepared. Otherwise, sudden temperature change could damage glass liner.
7. Never use ice cubes in carafe.
8. Never fill carafe with carbonated beverages.
9. Never drink directly from carafe. Always check beverages for broken glass before drinking.

## CLEANING AND MAINTENANCE

### Daily

Always unplug coffee maker and allow to cool before cleaning. Wash filter basket in hot, sudsy water. Rinse inside of thermal carafe with lukewarm water. Wipe coffee maker and outside of thermal carafe with damp cloth, then dry. Never put coffee maker or thermal carafe in water or in the dishwasher. For hard to remove stains, use a plastic mesh pad or a cloth dampened in vinegar. Do not use metal cleaning pad or abrasive cleaners.

### Monthly

Minerals found in water can clog coffee maker or reduce its efficiency. To prevent this, fill thermal carafe with 2 cups vinegar. Add cold water to top. Pour water/vinegar mixture into reservoir opening. Place empty thermal carafe (with lid securely closed) on platform and press “ON” button. After water/vinegar mixture has been cycled through, press “OFF” button. Rinse by cycling through 2 or 3 more carafes of plain cold tap water. Do not pour any liquid other than cold tap water or water/vinegar mixture into reservoir opening when cleaning.

# FEATURES AND BENEFITS

## 1. Patented Lid:

Allows coffee to brew into and be poured from carafe without opening or adjusting. Keeps coffee hot and flavorful for hours.

## 2. Reservoir Cover:

Simply lift to fill with water. Close cover once water has been added.

## 3. Filter Basket:

Swings open for easy insertion of coffee filter.

## 4. Water Window:

Magnified markings indicate water needed to make corresponding cups of coffee.

## 5. Thermal Insulated Carafe

## 6. Brew Pause

Stops flow of water from basket when carafe is removed from heater plate so a cup can be poured during brewing cycle.

## 7. Auto-Brew Cycle Program time to brew.

## 8. "ON" Indicator Light Illuminates when power is on.

## 9. LCD Readout

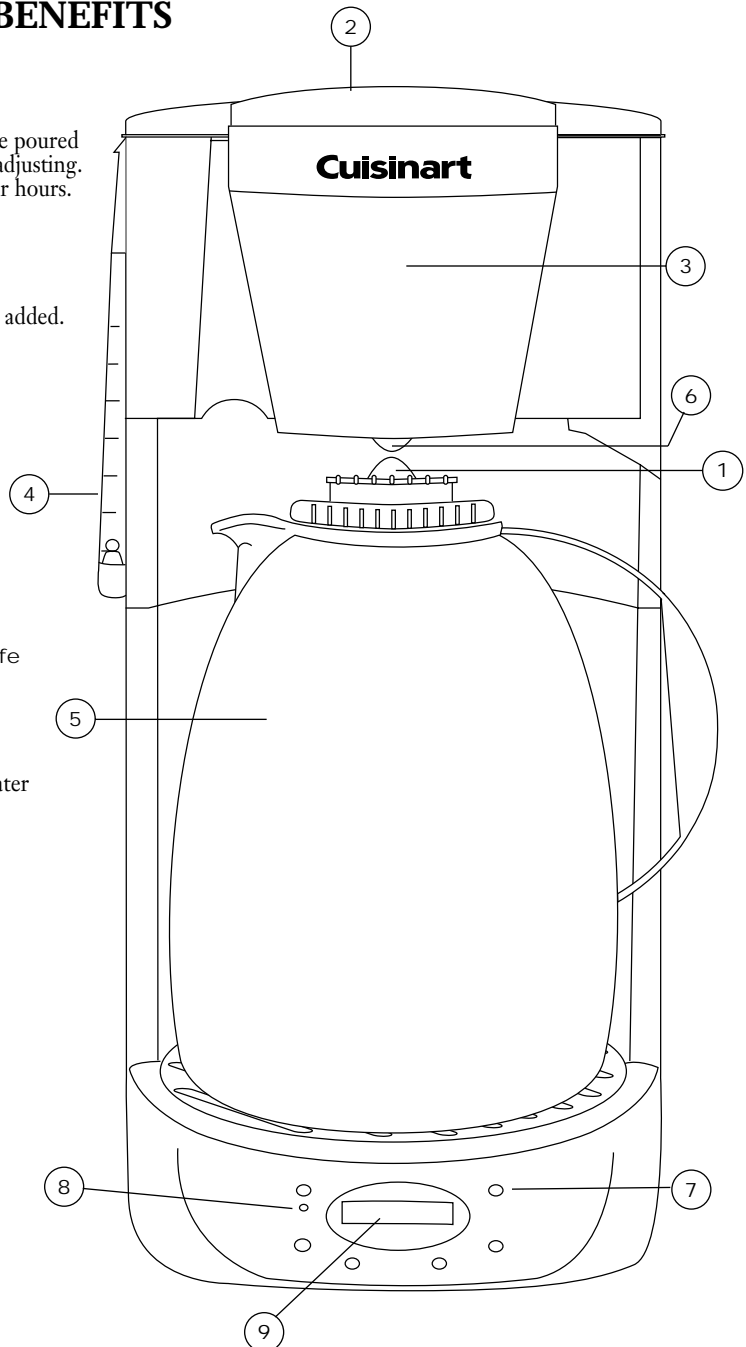

---

# WARRANTY

## THREE YEAR LIMITED WARRANTY

This warranty is available to consumers only. You are a consumer if you own a Cuisinart® Automatic Brew and Serve Coffee Maker that was purchased at retail for personal, family or household use. Except as otherwise required under applicable state law, this warranty is not available to retailers or other commercial purchasers or owners.

We warrant that your Cuisinart® Automatic Brew and Serve Coffee Maker will be free of defects in material or workmanship under normal home use for three years from the date of original purchase.

We suggest that you complete and return the enclosed warranty registration card promptly to facilitate verification of the date of original purchase. However, return of the warranty registration is not a condition of these warranties.

If your coffee maker should prove to be defective within the warranty period, we will repair it (or, if we think it necessary, replace it) without charge to you. To obtain warranty service, please call our Consumer Service Center toll-free at 1-800-726-0190 or write to:

Cuisinart  
150 Milford Road  
East Windsor, NJ 08520

To facilitate the speed and accuracy of your return, please also enclose \$10.00 for shipping and handling of the product (California residents need only supply proof of purchase and should call 1-800-726-0190 for shipping instructions). Please also be sure to include a return address, description of the product defect, product serial number and any other information pertinent to the product's return. Please pay by check or money order.

Your Cuisinart® Automatic Brew and Serve Coffee Maker has been manufactured to strict specifications and designed for use only with the Cuisinart® Coffee Maker parts for your model. These warranties expressly exclude any defects or damages caused by accessories, replacement parts or repair service other than those that have been authorized by Cuisinart.

These warranties do not cover any damage caused by accident, misuse, shipment or other than ordinary household use.

These warranties exclude all incidental or consequential damages. Some states do not allow the exclusion of or limitation of incidental or consequential damages, so the foregoing limitation or exclusion may not apply to you.

## CALIFORNIA RESIDENTS ONLY

California law provides that for In-Warranty Service, California residents have the option of returning a nonconforming product (A) to the store where it was purchased or (B) to another retail store which sells Cuisinart® products of the same type. The retail store shall then, at its option, either repair the product, refer the consumer to an independent repair facility, replace the product or refund the purchase price less the amount directly attributable to the consumer's prior usage of the product. If either of the above two options does not result in the appropriate relief to the consumer, the consumer may then take the product to an independent repair facility if service or repair can be economically accomplished. Cuisinart, and not the consumer, will be responsible for the reasonable cost of such service, repair, replacement or refund for nonconforming products under warranty.

California residents may also, according to their preference, return nonconforming products directly to Cuisinart for repair or if necessary, replacement, by calling our Consumer Service Center toll-free at 1-800-726-0190. Cuisinart will be responsible for the cost of the repair, replacement and shipping and handling for such nonconforming products under warranty.

## **BEFORE RETURNING YOUR CUISINART® PRODUCT**

If you are experiencing problems with your Cuisinart® product, we suggest that you call our Consumer Service Center at 1-800-726-0190 before returning the product for servicing. Often, our Consumer Service Representatives can help solve the problem without having the product serviced. If servicing is needed, a Representative can confirm whether the product is under warranty and direct you to the nearest service location.

**\* Important:** If the nonconforming product is to be serviced by someone other than Cuisinart's Authorized Service Center, please remind the servicer to call our Consumer Service Center to ensure that the problem is properly diagnosed, the product is serviced with the correct parts and the product is still under warranty.

# Cuisinart

S A V O R T H E G O O D L I F E™



COFFEE  
MAKERS

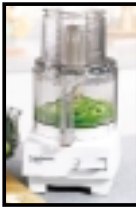

FOOD  
PROCESSORS



TOASTERS



HAND  
MIXERS



BLENDERS



COOKWARE



ICE CREAM  
MAKERS

Cuisinart offers an extensive assortment of top quality products to make life in the kitchen easier than ever. Try some of our other countertop appliances and cookware, and Savor the Good Life™.

©2001 Cuisinart  
Cuisinart® is a registered trademark of Cuisinart.

Cuisinart  
150 Milford Road  
East Windsor, NJ 08520  
Printed in China  
IB-3663B  
00CU13227